



APE Single Acting Diesel Impact Hammer

THE WORLD'S LARGEST PILEDRIERS

Model D36-26

SPECIFICATIONS

| | |
|---|----------------------------|
| Stroke at Maximum Rated Energy | 135 in (343 cm) |
| Maximum Rated Energy (Setting 4) | 89,303 ft-lbs (121.07 kNm) |
| (Setting 3) | 74,121 ft-lbs (100.49 kNm) |
| (Setting 2) | 58,940 ft-lbs (79.91 kNm) |
| Minimum Rated Energy (Setting 1) | 43,758 ft-lbs (59.33 kNm) |
| <i>(VARIABLE THROTTLE ALLOWS FOR INFINITE FUEL SETTING)</i> | |
| Maximum Obtainable Stroke | 150 in (381 cm) |
| Maximum Obtainable Energy | 99,225 ft-lbs (134.52 kNm) |
| Speed (Blows Per Minute) | 34-53 |

WEIGHTS (APPROXIMATE)

| | |
|--|--|
| Piston | 7,937 lbs (3,600 kg) |
| Anvil | 1,023 lbs (464 kg) |
| Anvil Cross Sectional Area | 367.94 in ² (2,373.80 cm ²) |
| Hammer Weight (Includes Trip Device) | 17,500 lbs (7,938 kg) |
| Typical Operating (Weight With DB26 & H-Beam insert) | 20,152 lbs (9,141 kg) |

CAPACITIES

| | |
|--|------------------------|
| Fuel Tank (Runs on Diesel or Bio-Diesel) | 17.7 Gal (66.9 Liters) |
| Oil Tank | 5 Gal (18.9 Liters) |

CONSUMPTION

| | |
|----------------------|---|
| Diesel or Bio-Diesel | 2.64 Gal/hr (9.9 Liters/hr) |
| Oil Tank | 0.26 Gal/hr (.9 Liters/hr) |
| Grease | 8 to 10 Pumps Every 20 Minutes of Operation Time. |

STRIKER PLATE FOR DB26

| | |
|-----------|---|
| Weight | 628 lbs (285 kg) |
| Diameter | 22.5 in (57.15 cm) |
| Area | 398 in ² (2,567.74 cm ²) |
| Thickness | 6 in (15.24 cm) |

CUSHION MATERIAL

| | |
|--------------------------|---|
| Type/Qty | Micarata / 2 each |
| Diameter-DB32 | 22.5 in (57.15 cm) |
| Thickness | 1 in (2.54 cm) |
| Type/Qty | Aluminum / 3 each |
| Thickness | 1/2 in (1.27 cm) |
| Diameter | 22.5 in (57.15 cm) |
| Total Combined Thickness | 3.5 in (8.89 cm) |
| Area | 491 in ² (3,167.74 cm ²) |
| Elastic-Modulus | 285 ksi (1,965 mpa) |
| Coeff. of Restitution | 0.8 |

DRIVE CAP

| | |
|--------|--------------------|
| DB 26: | 1,076 lbs (488 kg) |
|--------|--------------------|

INSERT WEIGHT

| | |
|--|--------------------|
| H-Beam Insert for 12" (305mm) and 14" (355 mm): | 948 lbs (430 kg) |
| Large Pipe Insert for the Sizes 12" to 24" Diameter: | 1,830 lbs (830 kg) |

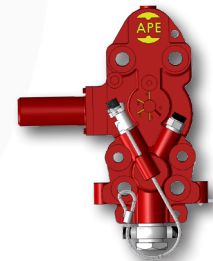
MINIMUM LEADER SIZE/OPERATING LENGTH

| | |
|---------------------------------------|---------------------------------|
| Minimum Box Leader Size | 8 in x 26 in (20.32 cm x 66 cm) |
| Operating Length with Base and Insert | 354 in (900 cm) |

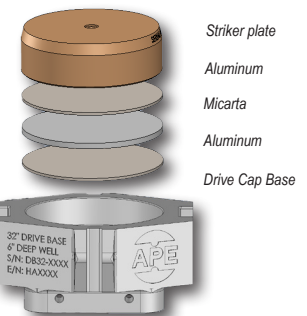


Image may not represent actual Model

Optional Variable Throttle Control



Drive Base Assembly



Striker plate
Aluminum
Micarta
Aluminum
Drive Cap Base



Specifications may vary due to site conditions, specific hammer conditions or product set up.
Specifications may change without notice.
Consult the factory for details on any specific product (800) 248-8498.
Copyright © 2022 American Piledriving Equipment Inc. All Rights Reserved



WWW.AMERICANPILEDIVING.COM
Ape@americanpilediving.com