

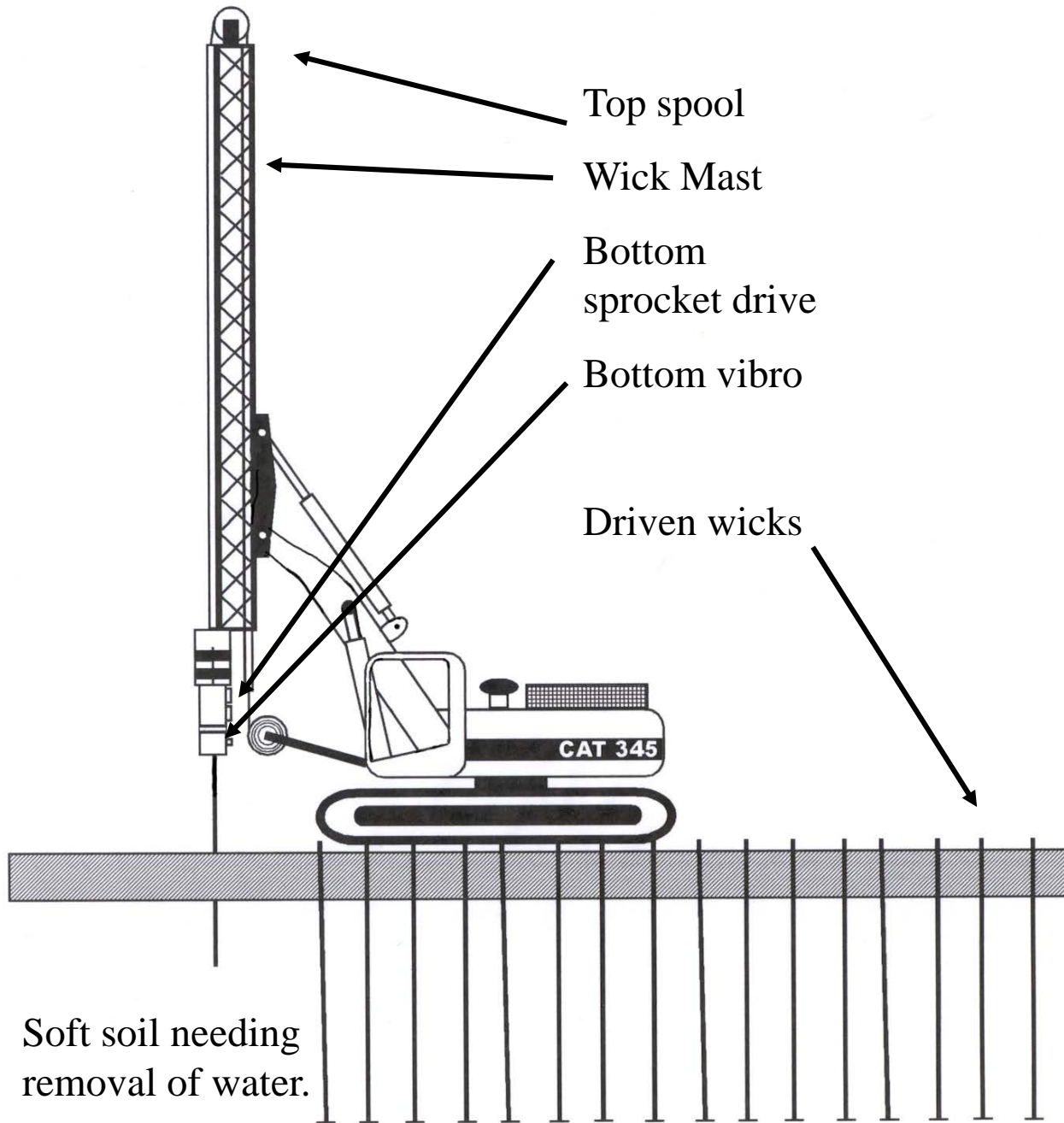

AMERICAN
PILEDIVING
EQUIPMENT, INC.
Seattle, Washington
USA
253 872-0141
www.apevibro.com

**A study of wick drain
machines and a
presentation of APE's new
bottom drive machine.**



Wick drain concept

Consolidate soft compressible soils using vertical wick drains

Note: This is a drawing of APE's bottom drive rig.

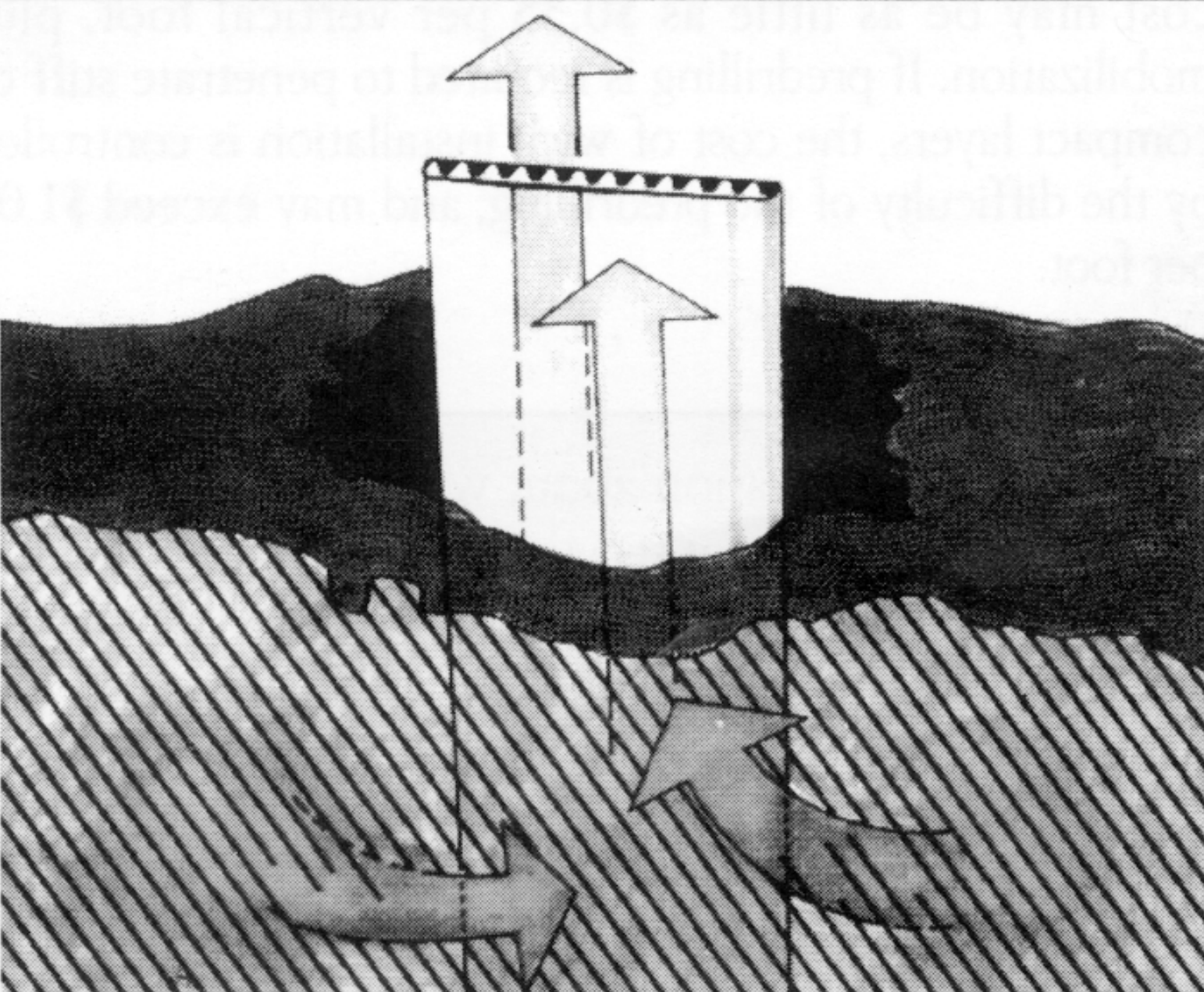

Drawing and pictures of wick drain (US Wick)

Video of Actual Wick Inserted In The Ground





SOILDRAIN
Advanced Vertical Soil Drains
The SOILDRAIN vertical drains for effective consolidation
of soft soils are specifically designed to maintain
constant vertical permeability in even the
most challenging and high permeability in even the
most challenging and high permeability in even the

SOILDRAIN 707
 SOILDRAIN 708
 SOILDRAIN ST709
 SOILDRAIN 710

Soil drain ST709



Wick drain comparisons

Note: Wick drain on right has heavier plastic but identical fabric.



HONGPLAST GEO DRAIN GD 75

Wick drain manufactured in Singapore. Notice the excellent depth of the channels in the core. The deeper the core the faster the drainage flow. The filter fabric also plays a role in the specifications of each type of wick drain.

HONGPLAST® GEO DRAIN GD 75

	Unit	Specifications	Test Method
Physical Properties :			
Drain Body	Resin	Polypropylene	
Colour	Std	Translucent	
Filter Jacket	Type	non-woven	
Weight	g/m (min)	80 (core + filter)	
Thickness of Filter at 20kPa	mm	0.48	ASTM D-5199-91
Width	mm	100±2	
Overall Thickness	mm (min)	3.3	
Elongation of Drain at 100kg/10cm	%	5	
Tensile Strength Drain	KN	2.5	ASTM D1682 : 1975
Compressive Strength Drain	KN	22	10% Vertical Strain
			ASTM D1621-1973
Fabric Tensile (Dry)	kgf/cm	>5	ASTM D1682-64
Fabric Tensile (Wet)	kgf/cm	>4	ASTM D1682-64
Fabric Elongation (Dry) at 3kg/cm	%	<2	
Fabric Elongation (Wet) at 3kg/cm	%	<2	
Permeability Properties :			
Permeability	cm/sec (min)	1.1×10^{-2}	
Water Permittivity	s ⁻¹	2	ASTM 4491-92
Discharge Capacity at 350kPa	m ² /sec	56×10^{-6}	
Discharge Capacity Deformed	m ² /sec	39×10^{-6}	30% Vertical Strain
Pore Size O ₉₅	microns	<75	ASTM D4751-87

Example Spec sheet on drain

DISCHARGE CHARACTERISTICS

measured by the Nanyang Technological University

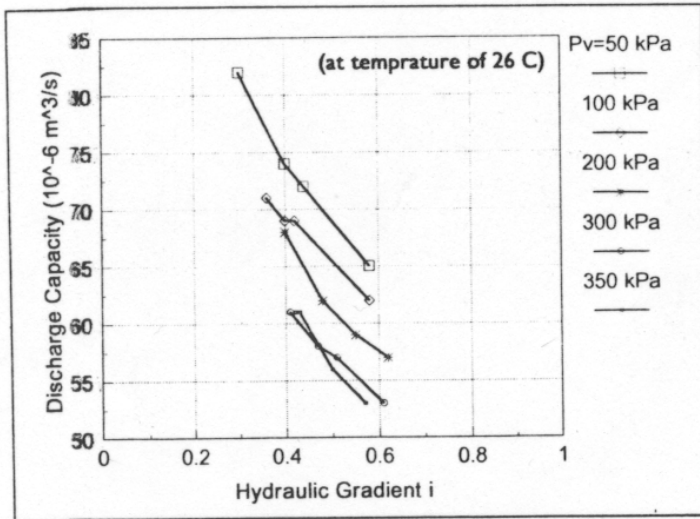

Fig. 1 Test Results for Hongplast Geo Drain 75 by 100x100 Tester

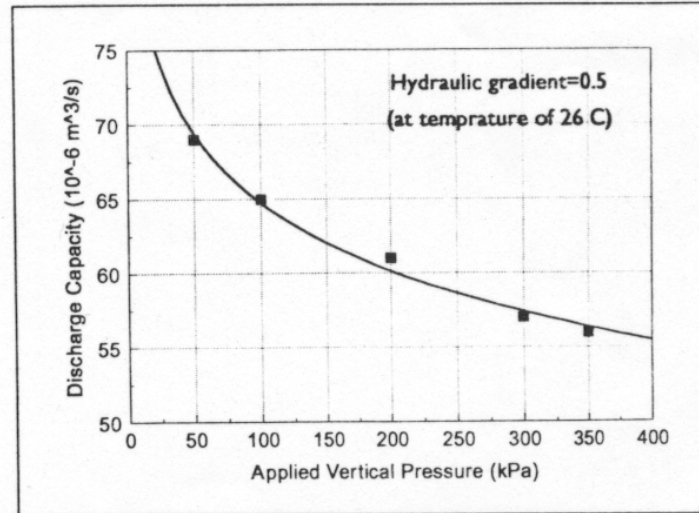

Fig. 2 Test Results for Hongplast Geo Drain 75 by 100x100 Tester

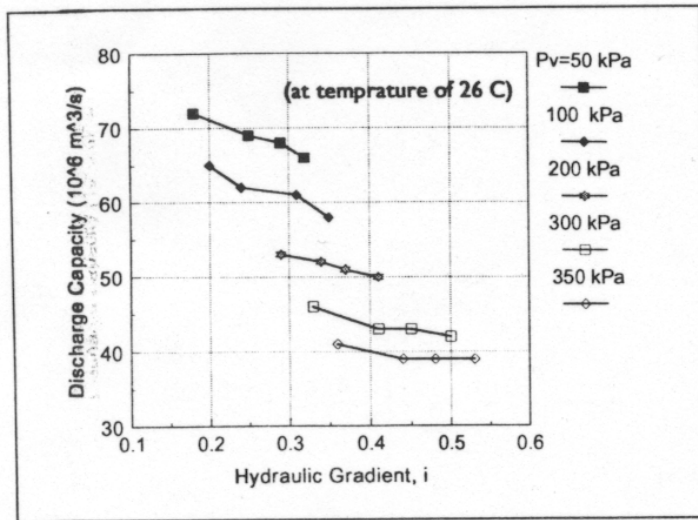

Fig. 3 Test Results for Hongplast Geo Drain 75 by Buckling Tester

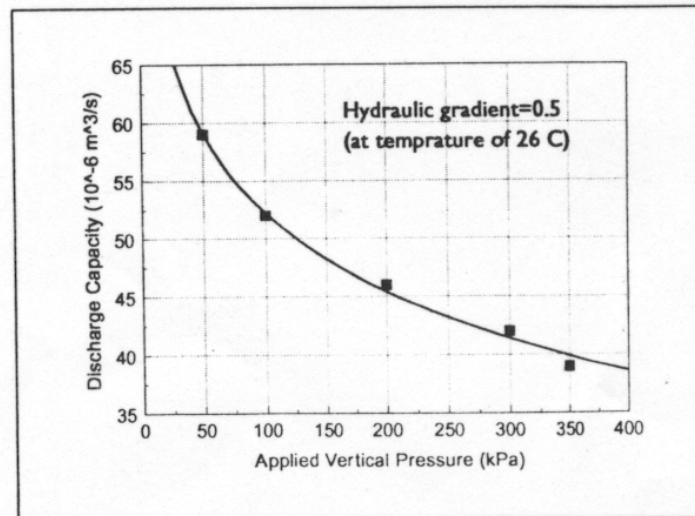



Fig. 4 Test Results for Hongplast Geo Drain 75 by Buckling Tester

Discharge characteristics example.

**Note: The Industry Offers
Many Types of Wick Drains
on the Market. Consult With
Your Wick Drain Supplier for
Specifications.**



**Wick
mandrel fin
where vibro
mounts.**

Top drive vibro wick rigs



Mast

Vibro

Crane

Boom

Mandrel

**Top drive
vibro wick
drain installer
using H-beam
lead and
finned
mandrel and
small vibro.**



Simple wick drain rig using a vibro.

Headlock

Vibro clamped to mandrel

Rooster Sheave

Wick drain mast made of simple H-beam

Spotter

Power unit for vibro

Wick spool

Video Shows Inserting Wick Into Ground.

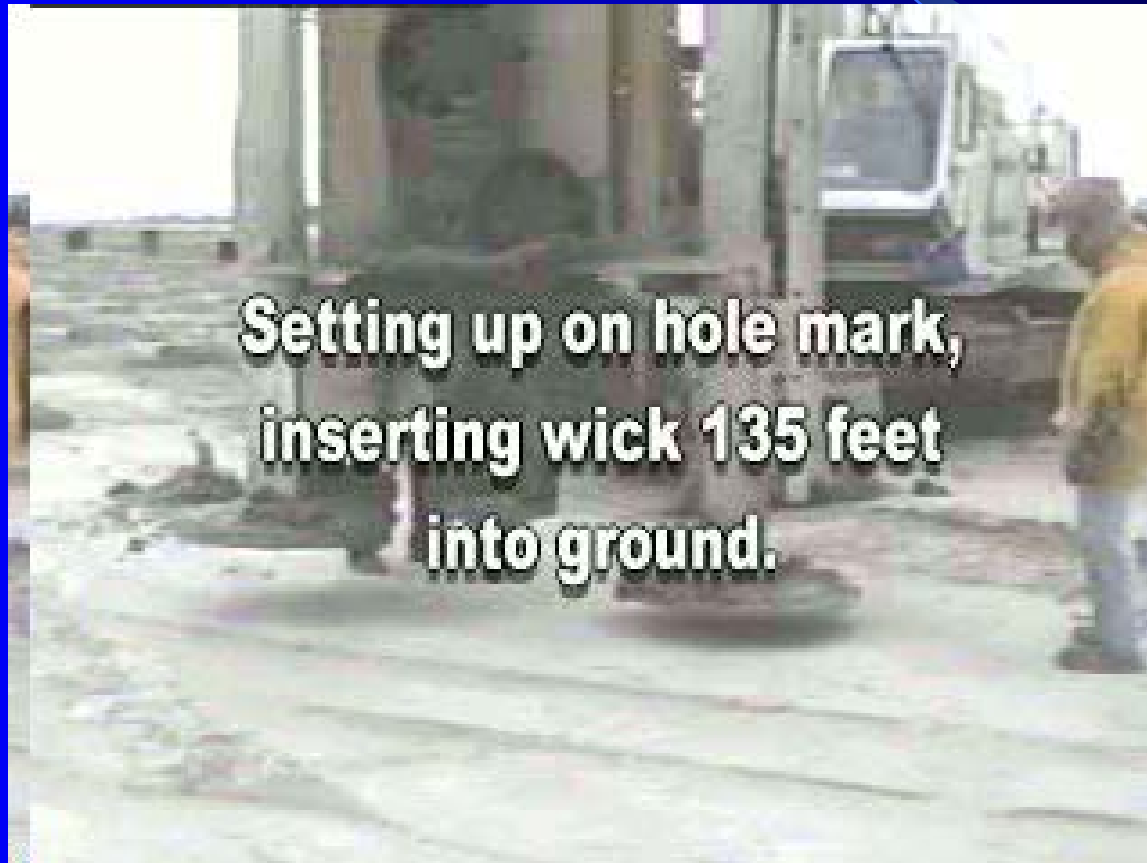



View of H-beam wick leader



This is a standard crawler crane that has been converted to a wick drain rig. It consists of a long H-beam mounted onto the crane in a fixed configuration. A mandrel housing has been welded onto the front of the H-beam and a 2" by 5" mandrel has been installed in the housing. A fin is welded to the top of the mandrel. A vibro is attached to the fin. Wick runs up the middle of the beam.

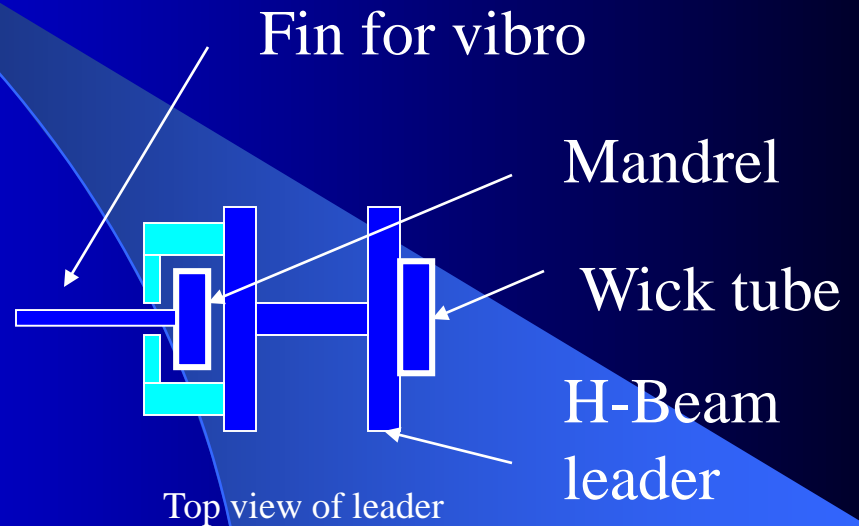

Top drive vibration only wick rig

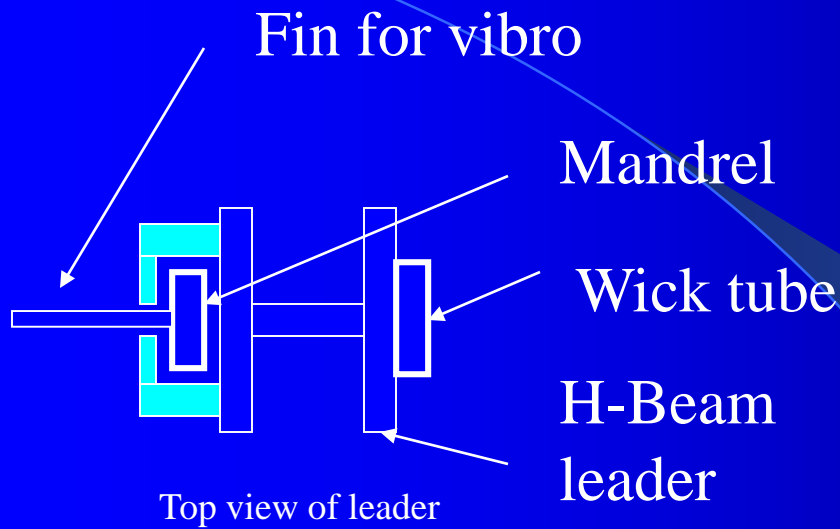

List of problems:

Vibro energy not axial- off center loading

Side loads cause excessive wear

Fin breaks all the time

Speed depends on crane winch

Top heavy- long wicks need big crane

Some jobs do not like vibration

No crowd capacity

Cannot be rapidly boomed down to feed broken or damaged wick

Must climb the leaders to service

Problems with top drive vibro only wick machine



Top Drive vibration only wick installer using crawler crane



Top drive dual vibro rig driving two wicks at once.



Top drive vibro driving two wicks at once.



Wick Mandrel

Electric vibro

Sheet pile clamp mounted
sideways on bottom of vibro

Electric vibro used to
drive wicks. (not a
good design)
Used at Junk Bay,
Hong Kong.
Designed by
Express Builders.
1993

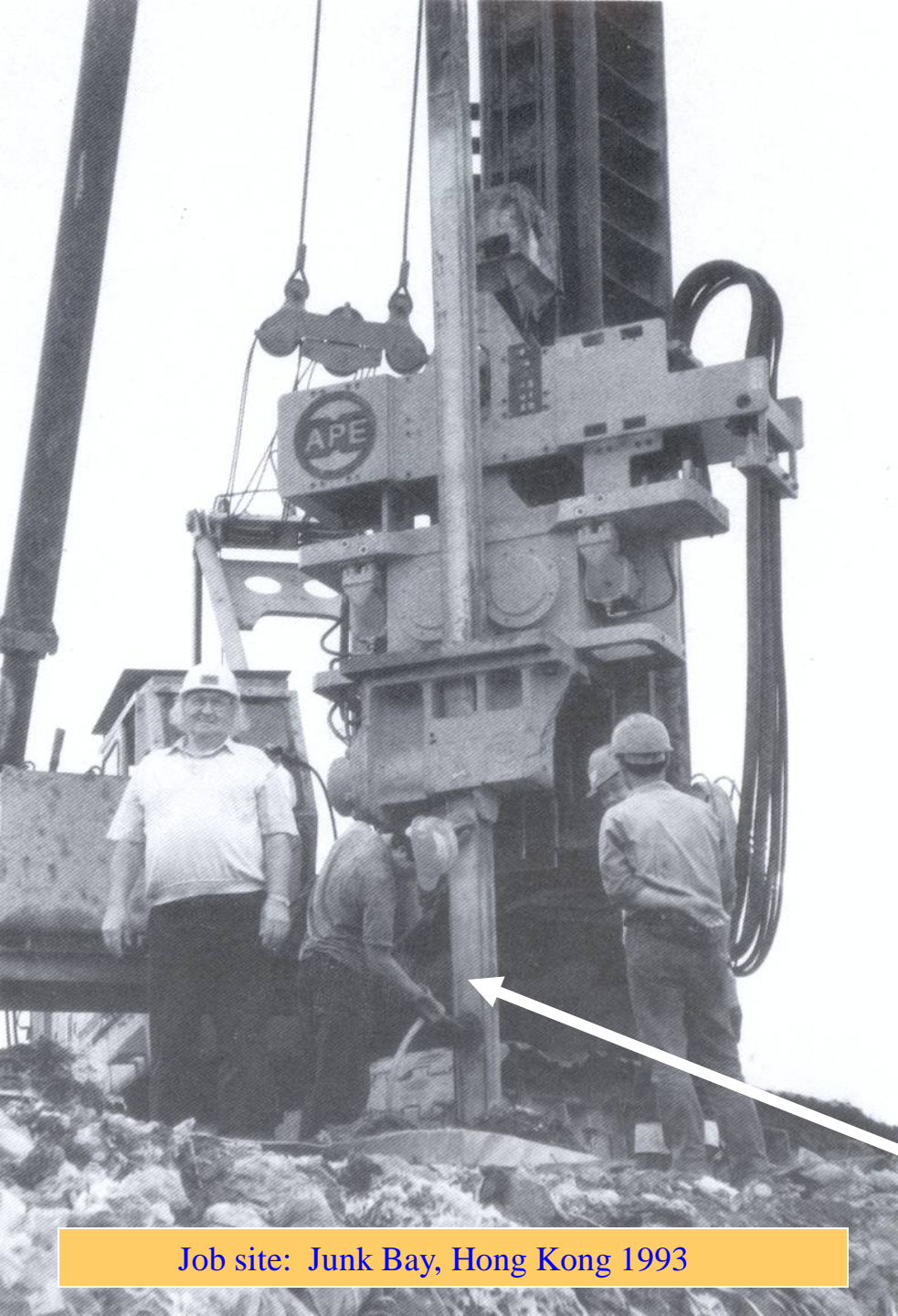

APE 150 drives wicks in Hong Kong. The 150 has a clamp attachment with a hole in the center to allow the 50 meter (150 feet) mandrel to pass through it. The pile driving rig mast was too short to support 50 meter mandrel. The mandrel stuck up above the rigs mast. The vibro drove the mandrel and was then released, raised and re-clamped to the mandrel to drive. It was a three step process.

Job site: Junk Bay, Hong Kong 1993

Wick Mandrel



APE equipment installed 250 foot (83 meter) wicks using standard pile driving leads and an APE top drive vibro. This was for a project in Salt Lake City, Utah in Oct 1993.



APE top drive installing 85 meter wicks.



Another view of APE equipment in Salt Lake. Top drive vibro only.
Note that APE power unit is mounted on back of 300 ton crane.



Standard APE Model 50 vibro is mounted to a fin that is welded to the mandrel. The leads were APE Model 26" leaders. Job performed by Nilex Corporation. All equipment is APE.

Location: Salt Lake City, Utah

Date: 1993



APE top drive vibro rig 85 meters



APE top style drive at Craney Island August 2000



This is the APE Model 50 top mounted vibro fitted to 170 feet of APE Model ST 75 leads driving at Craney Island August 2000



APE top mounted Model 50 fitted with 170 feet of APE ST 75 leads mounted on Link belt crane at Craney Island

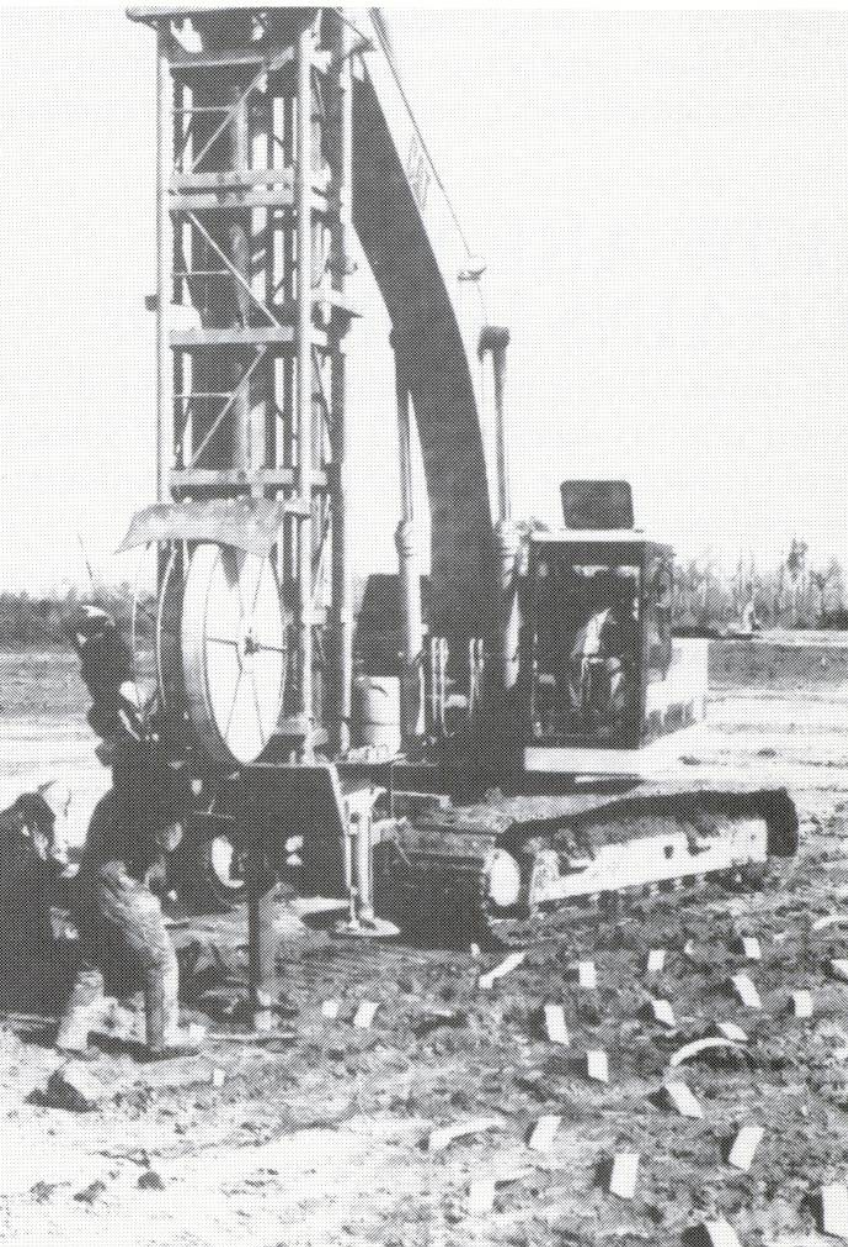

The is a static wick drain installer that pushes the wick mandrel into the ground using chain drives and planetary. This rig originated in Sweden. It is also known as the Ali-Mak made by Linden Alimak of Sweden.

This type of rig is used today by US Wick Inc and others.

Static type wick installer



Ape converted this chain drive rig to a top drive vibro rig to install wicks in Hong Kong in 1993 for Express Builders. An APE Model 150 drove 50 meter wicks while mounted on the front of these leads which were mounted to a crawler crane. No chains were used.



Static rigs working in Hong Kong



Static rig working in Hong Kong

This rig uses two chain drives mounted from top to bottom. Cables are used to stabilize the leader system. Wick is exposed in back of leads as shown.

Static rigs in Hong Kong

These rigs have great difficulty driving wick drains in hard soil. Note electric vibro seen in right of this picture driving a pipe into the ground. This method was used to pre-drill holes for the wick machines.





Close up chain drive system

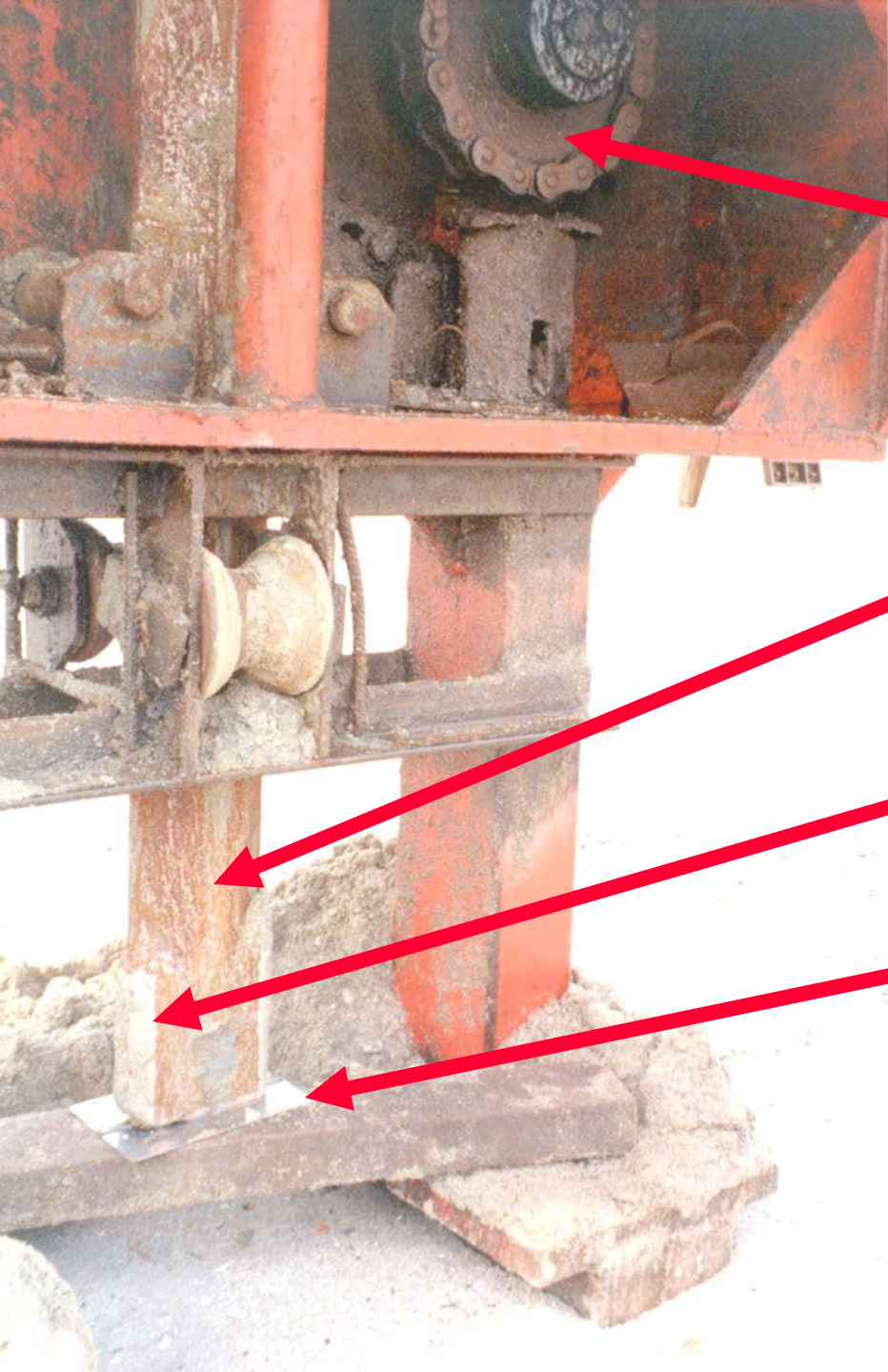

Chain and gear used to force mandrel into ground.

Diamond shaped mandrel.

Hard faced welding to increase life of mandrel.

Wick drain shoe.

Static rig components



Alimak rig
mounted to
245 CAT
This rig is not
self erecting.

Wick spool (Alimak rig)



Wick going up the lead

Wick spool

Wick drain



This is a recent picture of an Alimak rig. It is not self erecting, heavy, and has ability to vibrate. Double Chains run from top to bottom.

Picture is from Singapore.



Wick drain shoe

Installing shoes on wick drain

Video Shows Installing Shoe Plate.





Wick drain

Top of drain just after it has been cut off. The wick drain is cut using a hand blade.

A Working Wick Drain.



Installing the shoe.

Once the wick drain has been cut, a new shoe is attached the end of the wick roll. The rig is then moved to a new location for installation of the next drain.



Wick shoe

The wick is threaded through the handle that is part of the shoe. No staple is required. Once the wick has been threaded, one of the crew members pulls back on the wick roll which forces the shoe up into the wick drain mandrel as shown in the next slide.

Installed Shoe



Mandrel

Shoe

(anchor plate)

The wick drain shoe (also called an anchor plate) is simply a sheet metal plate with a handle welded on it. The wick is threaded through the handle. Once threaded, the wick is pulled backwards to pull the shoe tight against the bottom of the mandrel.



Splicing wick

Wick drain is supplied on rolls. Each roll will hold about one thousand feet of drain or 330 meters.

Once the roll is used up, a splice is necessary to add the next roll.

To splice, cut the end of the previous roll at an angle and stuff it inside the end of the new roll. Then staple them both together as shown.



Static/Vibro top drive rig

Notes: Vibro mounted on top of self erecting mast on excavator plus chain drive.

Note: Vibro axial forces not transferred to center of mandrel. Heavy wear items due to side loading. Chains are present from top to bottom.



Self erecting static/top drive vibro with chain drive.

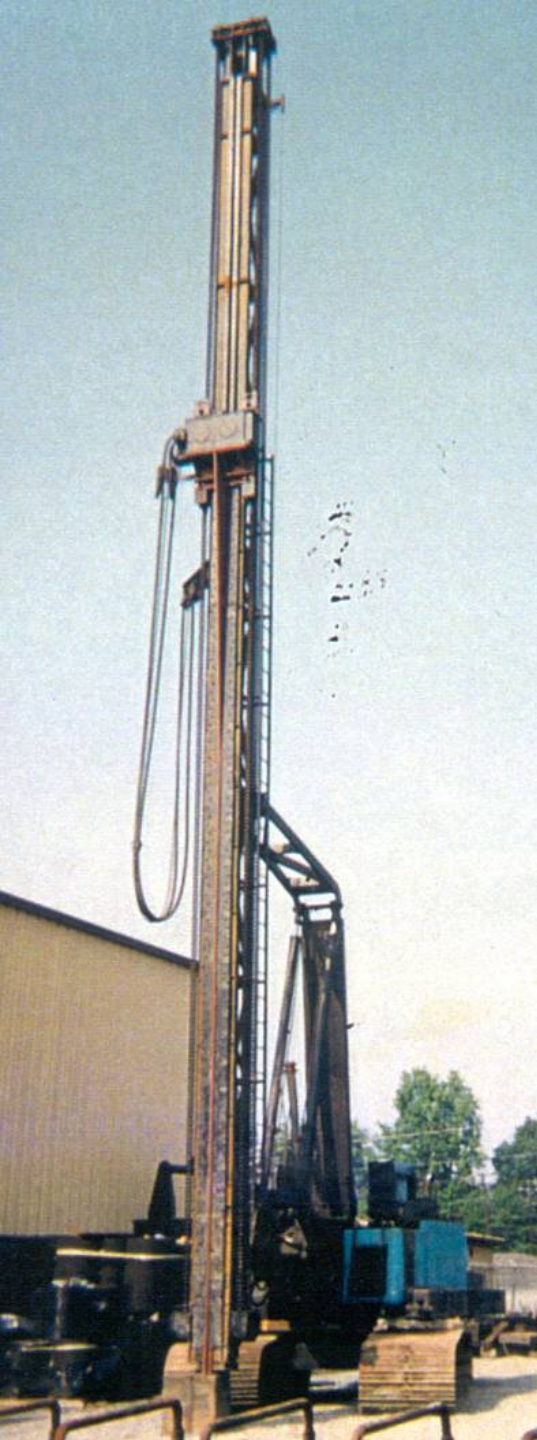

Static chain
drive with top
drive vibro
mounted on self
erecting mast.
GTA

US Patent
5213449

Static
bottom
gear drive
concept

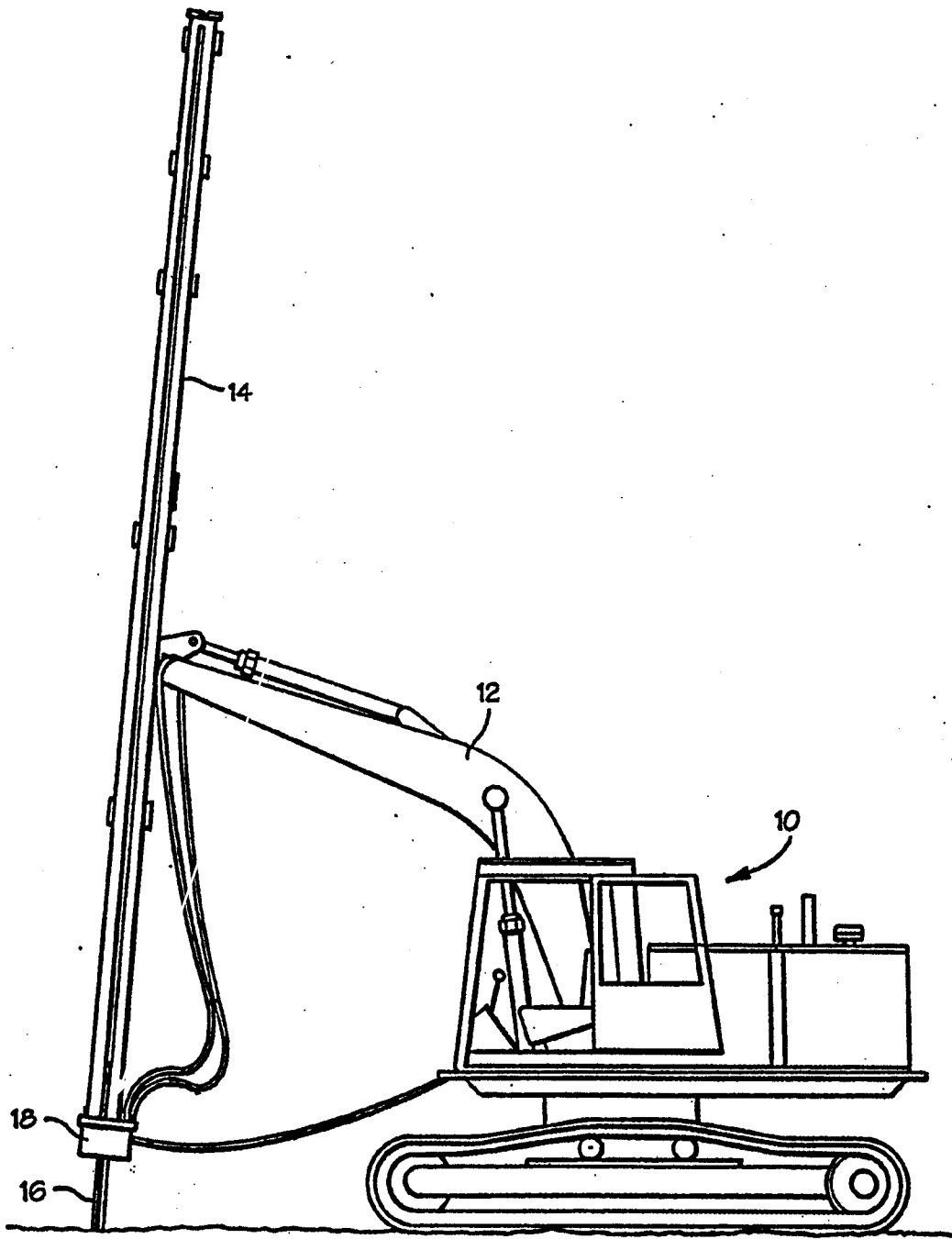

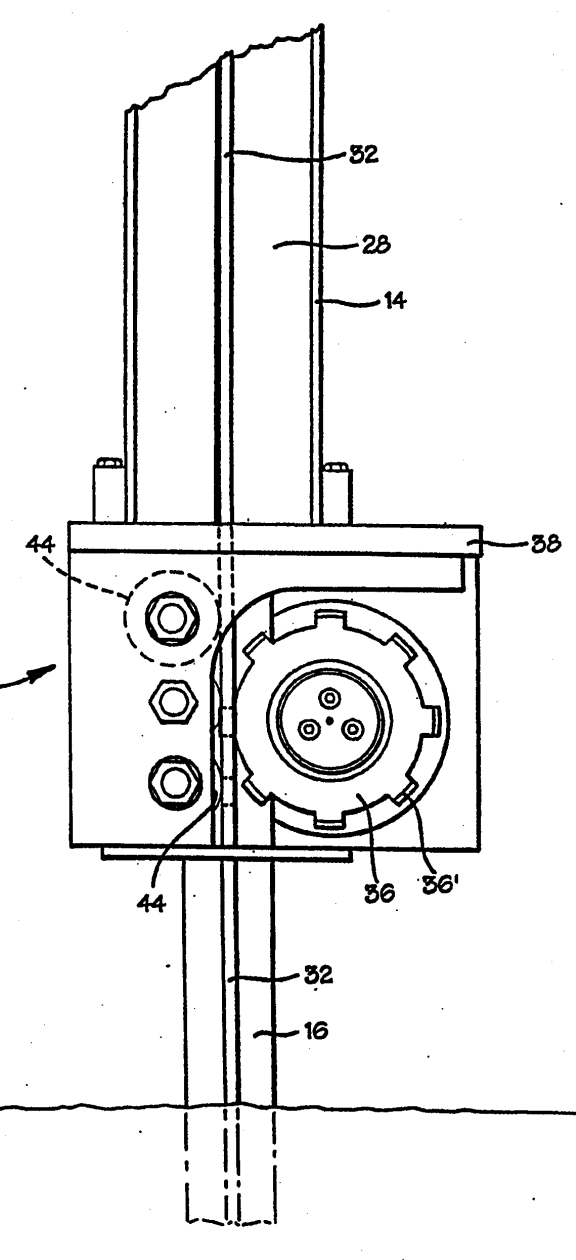

Static bottom drive gear

This is purely a static gear drive rig for extremely soft soils. Forces are off center which results in failures. Other problems are a very large foot print, limited speed and excessive maintenance. Expensive mandrel costs also.



Self erecting mast

Top drive vibro
mounted directly
to wick drain
mandrel

Fin plate for added
support

Chain drive
system

Static/Top drive vibro components



APE bottom drive mounted to Mantis 70 ton crane

Inserting Wick 130 Feet in 38 Seconds,
Retracting Mandrel in 32 Seconds.



Note: The list of prior art continues on additional pages of the patent.

- [54] **APPARATUS FOR INSERTING ELONGATE MEMBERS INTO THE EARTH**
- [75] **Inventor:** John L. White, Kent, Wash.
- [73] **Assignee:** American Piledriving Equipment, Inc., Kent, Wash.
- [21] **Appl. No.:** 08/900,481
- [22] **Filed:** Jul. 25, 1997
- [51] **Int. Cl.⁷** E02D 7/00; E02D 7/26
- [52] **U.S. Cl.** 405/232; 405/50; 254/95; 175/55; 175/56
- [58] **Field of Search** 405/50, 198, 232; 254/95, 97; 175/19, 55, 56, 162; 166/71, 77.1

[56] **References Cited**

U.S. PATENT DOCUMENTS

628,962	7/1899	Speer .	
1,288,989	12/1918	Rees	254/97
1,322,470	11/1919	Schenk .	
1,654,093	12/1927	Reid .	
1,903,555	4/1933	Robertson .	
2,577,252	12/1951	Kjellman .	
2,952,132	9/1960	Urban .	

(List continued on next page.)

FOREIGN PATENT DOCUMENTS

0172960A1	3/1986	European Pat. Off. .
0526743B1	8/1995	European Pat. Off. .
838717	3/1939	France .
2560247	2/1984	France .
42349	1/1938	Netherlands .
65252	1/1950	Netherlands .
65252	2/1950	Netherlands .
7707303	7/1977	Netherlands .
7710385	9/1977	Netherlands .
7805153	5/1978	Netherlands .
7707303	1/1979	Netherlands .
7805153	11/1979	Netherlands .
92-16944	9/1992	Rep. of Korea .
1027357	7/1983	Russian Federation .
1027357A	7/1983	Russian Federation .

2003769A	8/1978	United Kingdom .
2023496A	1/1980	United Kingdom .
2028902B	8/1982	United Kingdom .
WO87/07673	12/1987	WIPO .
WO88/05843	8/1988	WIPO .

OTHER PUBLICATIONS

A series of photographs identified by reference No. APE01147 through APE01159. (Undated).
 Japanese language brochure entitled "Castle Board Drain Method", (Aug. 1976).
 "The 1st Report on the Treatment of Soft Foundation of Juck Hyun Industrial Site" (Ref. Nos. APE00854 through APE00856).
 Schematic drawings identified by Ref. Nos. APE01038, APE01039, and APE0339. (Undated).
 A report identifying systems for driving mandrels carrying wick drain material into the earth, identified by Ref. Nos. APE0510 through APE0536. (Undated).
 Korean language document identified by reference No. APE00864 through APE0089;1 (From 1982 to 1997).

Primary Examiner—David Bagnell
Assistant Examiner—Jong-Suk Lee
Attorney, Agent, or Firm—Hughes & Schacht, P.S.; Michael R. Schacht

[57] **ABSTRACT**

A system for inserting elongate members into and removing elongate members from the ground. The system is a bottom drive system that is capable of applying crowding or extraction forces to the elongate member while at the same time vibrating the elongate member along its axis. A vibratory assembly is mounted by a shock absorbing assembly to a support base. A gear or other type of drive assembly is mounted on the vibratory assembly. Vibratory forces generated by the vibratory assembly are applied to the elongate member through the drive assembly, causing the drive assembly to vibrate with the elongate member. The elongate member extends through the center of the vibratory assembly such that the vibratory forces have a vibratory axis that is aligned with the lengthwise axis of the elongate member to prevent torsional or twisting forces from being applied to the elongate member.

Patented features include:

"The mandrel extends through the center of the vibratory assembly such that the vibratory forces have a vibratory axis that is aligned with the lengthwise axis of the mandrel to prevent tensional or twisting forces from being applied to the mandrel."

FIG. 8

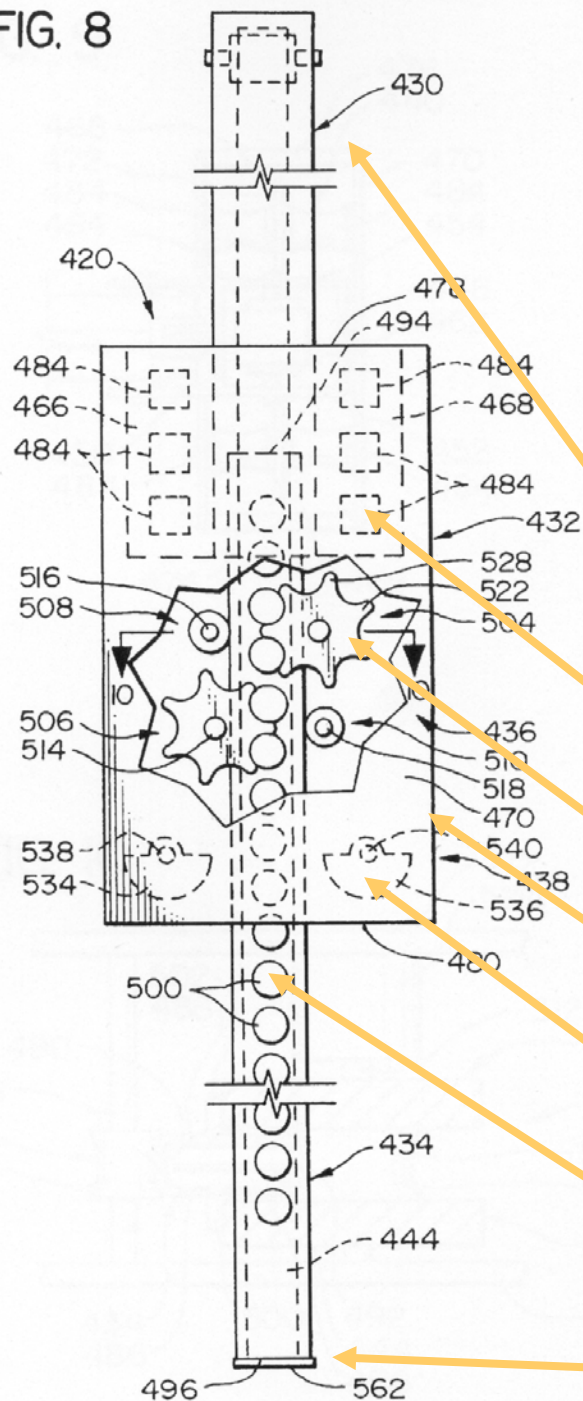

Patent drawing shows basic components

Wick drain mast (mounts to crane)

Vibro rubber suspension system

Sprocket drives

Vibro with hole in center

Vibro eccentrics

Mandrel with male sprocket rollers

Wick drain shoe

Close up of
APE sprocket
drive with
mandrel.

Please note
that only one
sprocket set is
shown in this
photo but in
actual use
there is at least
two sprocket
drives- one on
each side of
the mandrel to
provide perfect
axial loading.



View Of Sprockets In Action.



FIG. 9

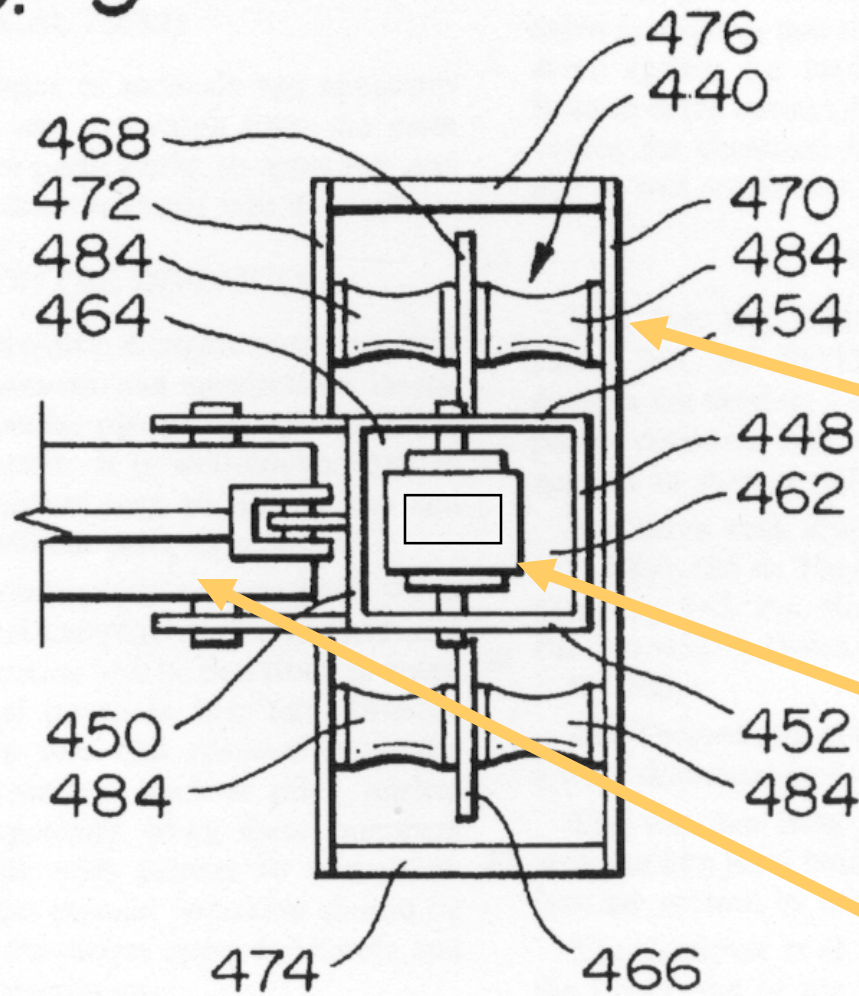

Top view

Vibro suppressor with rubbers

Mandrel

Crane or excavator boom pinned to mast

Top view one side of sprocket system.

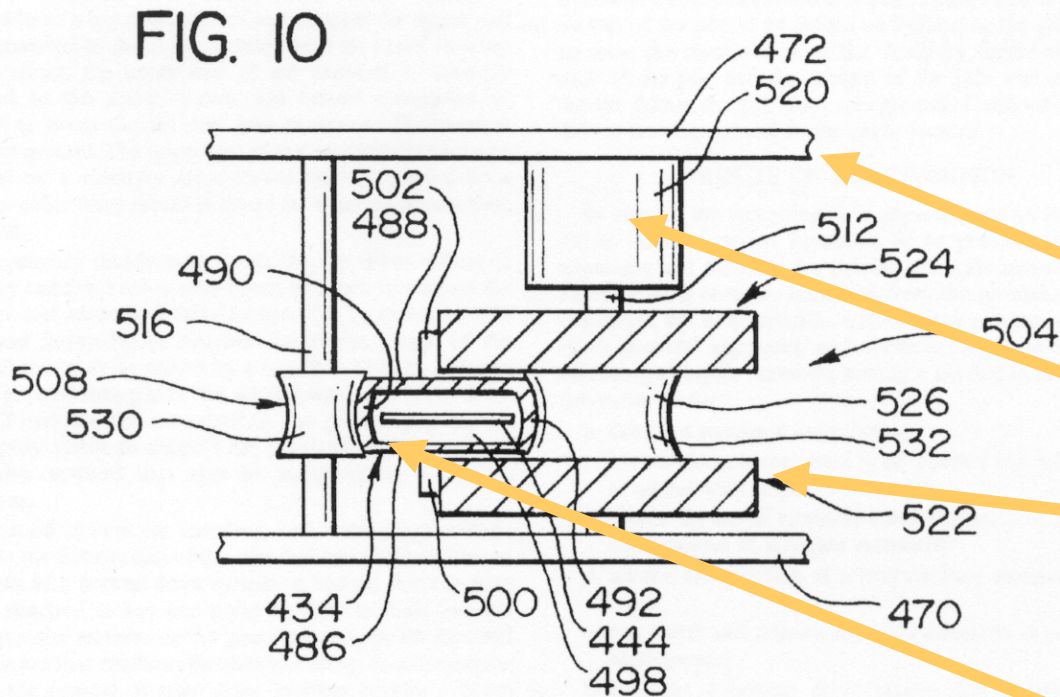

Sprocket housing

Hydraulic motor

Dual sprocket drive

This sprocket is on both sides of the mandrel.
Only one side is shown in this drawing.

Mandrel with male rollers attached



View of controls for APE wick bottom drive

APE bottom drive



Sprockets.
Mandrel not
installed in this
photo.

Vibro gearbox. Note
that sprockets vibrate
with vibro.





APE bottom
drive delivers
all forces,
static and
vibration
directly down
center of
mandrel.



This is a look at the APE bottom drive vibro. The drive sprockets are not installed.

The motors that turn the drive sprockets use cam track technology. There are no reduction drives, no planetary or gear boxes- just direct fluid-to-torque cam track hydraulics.

Two Motor Model for short wicks.



APE two motor system



Pat Hughes with APE wick machine.



APE bottom drive static/dynamic wick drain rig is shown here being used as a regular vibro pile driver installing H-beams.

The sprocket drives are not being used at all. This was just a demonstration to show that our rig can be used for other things beyond wick installation.

APE power unit for wick machine





John White receives patent on APE bottom drive system Mar 2000





APE bottom drive at Craney Island August 2000



APE bottom drive with four sprockets. Out riggers not needed but added for safety. For shorter wicks, it is not necessary to have four gear drives. This system shown in this photo is capable of raising the crane completely off the ground. This system can drive through extremely difficult soil conditions.

Added Power From The APE Vibro.





160 feet APE wick drain leads being stood up at Craney Island August 2000. **Note: self erecting – no help from other crane.**



**APE bottom drive driving wicks at
Craney Island August 2000**

Craney Island August 2000



**135 feet down,
135 feet up,
wick installed.**



**Photo showing jobsite at Craney Island with
4 million feet of wick.**



**APE bottom drive wick machine working at
Craney Island August 2000**

Fast Set-up For Next Hole.



Higginson Buchanan
Inc.





APE Bottom drive wick machine mounted on a Mantis 70 ton crane.
Higgerson Buchanan Inc. Chesapeake, VA









Close up view of APE leader system with wick drain mandrel housing on one end and wick drain feeding tube mounted inside. Leads weigh 75 lbs per foot. Leads include full length ladder and cast steel pin connections. These leads are also used for pile driving.

Advanced wick installation techniques

Installing wick drain is an art. One must have knowledge and experience to install wick drains. This is because the installation procedure changes with the different types of soil conditions and the depth of the drain. Some situations require pre-drilling of holes to get through hard layers of soil. Other situations may require adding water to the top of the mandrel to prevent blow in of the soil at the mandrel tip. Wick shoes that work in some places may not work in others. A larger shoe that is made of a heavier material may be required. Some drain types may be better for a particular type of soil while others may be too weak to install productive without breaking.

Please consult with us before starting your next wick project.

APE Bottomdrive Wick Drain Installer

for installing wick and other types of drains in extremely difficult soil conditions

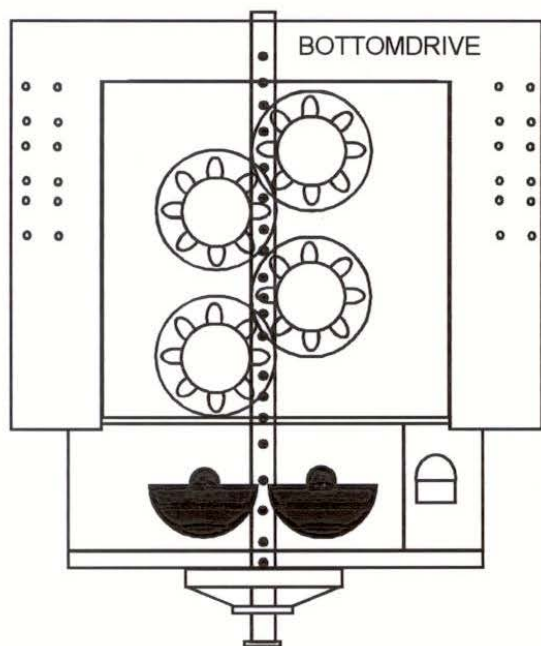

SPECIFICATIONS:

APE wick installer

Operating Dynamic force @ 1350 cpm	25 tons
Maximum Dynamic force: @ 1800 cpm	46 tons
Eccentric moment:	1000 inch pounds
Operating Frequency (variable)	0 to 1350 cycles per minute
Eccentric gear ratio:	1.36 to 1
Vibro motor displacement: (Rexroth 125)	7.62 cubic inches
Vibro motor hydraulic flow:	60 gpm
Suspended Weight :	9,500 lbs
Length:	6 feet
Width:	30 inches
Height w/four gear drive system & cleanout:	10 feet
Static force @ 2300 psi:	25 tons
Operating Combined static and dynamic force:	50 tons
Average cubic inches per rev of motor:	158.3
Displacement of all sprocket motors per rev:	630 cubic inches
Rack movement per hyd motor rev:	3.66 feet
Maximum sprocket motor rpm:	90 rpm
Maximum mandrel speed in feet per minute	330 feet
Maximum crowd/extraction force:	500 tons per square foot

Specifications
Deep drain
Model for
Difficult soils

SPECIFICATIONS POWER UNIT Model 350

Engine	Cummins
Power	350 HP
Operating speed	2100 rpm
Operating pressure	4500 psi
Maximum pressure (at reduced flow)	6000 psi
Sprocket drive hyd flow (all four)	230 gpm
Sprocket drive hyd flow (two)	115 gpm
Weight	10,000 lbs
Length	110 inches
Width	66 inches
Height	68 inches

Note: Mandrel speed is limited to 330 feet per minute because the MSE18-2 Poclain hydraulic motor maximum speed is 90 rpm. Crowd force is calculated at a pressure of 2300 psi. Additional crowd force is available at high pressures.

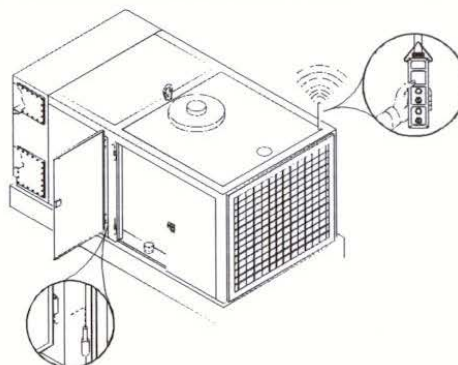

Note: Flow rates can be adjusted to meet any displacement requirements.

Features to consider:

- * *Drives and extracts wick mandrel directly through center of vibro gearbox for perfect axial loading.*
- * *Wick mandrel can be statically loaded and dynamically loaded at the same time while driving or extracting.*
- * *If soil is very soft, just use the gear drive to install. When difficult soil is reached, hit the vibrate button.*
- * *Designed to drive and extract wick drain mandrel in difficult soils.*
- * *Eliminates the need to pre-drill in most cases.*
- * *Vibrate right through hard layers of soil using the vibratory features.*
- * *Capable of driving and extracting a 30 meter wick drain in less than one minute.*
- * *Mounts to excavator or can be mounted on crane.*
- * *Only wear items are mandrel and sprockets which are very inexpensive.*
- * *No chain drives to maintain.*
- * *All loads are directly in the center of the mandrel. Extremely safe and trouble free.*
- * *Power unit can supply flow for drive sprocket motors, vibro motor, spotter and more.*
- * *Oversized radiator and hydraulic oil cooler designed to operate in the heat of Saudi Arabia.*



Corporate Offices:

7032 South 196th

Kent, Washington 98032 USA

(800) 248-8498 & (253) 872-0141 Fax (253) 872-8710

Visit our WEB site:

www.apevibro.com

e-mail: ape@apevibro.com

Due to constant improvements we must advise you to call APE for the latest available literature and specifications. 4/99

Features to consider.

“Sequence and Method of Installing Vertical Drains”

1. The Sequence of Drain Installation:

The sequence of installation will be as directed by the Project Engineer and/or specifications in conjunction with all “as-built” drawings and logs. All drains will go to maximum allowable/”anchorable” depths or until refusal as defined in the specs and logs. Installation is also contingent on obstructions both above and below ground.

“Method of Drain Installation”

2. Method of Drain Installation (using APE bottom drive)

- a) Thread the wick off the roll/spool, up the wick tube, and over the top roller and down through the mandrel.
- b) Place the wick through or around the anchoring device and tuck the loose end of the wick up into the mandrel about 6-8 inches. Pull the wick's excess slack tight through the mandrel and wick tube by reversing the wick roll by hand. By reversing the wick spool and roll, the anchoring device will retract up tight against the bottom tip of the mandrel. This will prevent dirt or mud from entering the mandrel during the insertion of the mandrel into the ground.

“Method of Drain Installation”

- c. Move the machine/mandrel to the specified wick drain location and insert the mandrel with anchoring device in place using static force (and/or vibratory force if necessary) into the ground to the desired depth.
- d. Extract the mandrel, leaving the anchoring device and the completed wick drain in place uncontaminated and at the proper depth.
- e. Cut the wick off at the contract-specified length above the working surface.
- f. Check the wick drain mast to make sure it is plumb. Use hydraulic controls to correct if not within specifications.

“Installation Equipment”

3. Installation Equipment: APE patent number 6039508

A) The wick drain installation equipment consists of an excavator mounted, bottom driven vibro wick insertion machine. The excavator will be a CAT excavator of suitable size consistent with the necessary capacity to handle the machine and leader. The excavator supplies all the necessary hydraulics to the bottom drive machine.

The bottom drive wick machine is made up of five major components: 1) the center hole vibro driver/extractor, 2) the sprocket drive, 3) the suppressor housing. 4) the mandrel, and 5) the mast or leader. A wick drain mast is attached to the machine and comes in various lengths according to the desired depth of the wick. The mast attaches to the excavator boom using a special attachment. All hydraulic valves and other operating components are mounted on the mast to eliminate the need to excessive modifications to the standard excavator components.

“Installation Equipment”

3. B) The mandrel, made of 2” by 5” wall high strength steel tube 3/8” thick. On both side of the wide face of the mandrel are round plates which the drive sprockets engage to move the mandrel up or down. The round plates are welded to the mandrel on both sides approximately six inches apart to mesh with the sprockets attached to the hydraulic drive motors.
4. Anchoring Device:

The anchoring device will be a 4” by 7” light gauge steel plate with a 1/2 inch wide handle welded in the center. This will protect the drain during installation. Anchoring devices may change in thickness depending on soil conditions.

“Installation Equipment”

5. Vertical Drain Splicing:

- A) The splicing of vertical drain will be demonstrated to the Project Engineer.
- B) The splicing will be done with regards to manufacturer’s suggested methods and in conjunction with Item 8-A.
- C) A sample of the splicing method has been enclosed with the vertical drain samples.
- D) The normal splice is 8 to 12 inches in length, overlapping the existing material to the newly introduced material, and stapling together vertically without restricting flow to water.
- E) The staples should crimp on the outside of the filter material to achieve a proper splice.

“Installation Equipment”

6. Wick Drain Material (U.S. Wick Drain – “Soil Drain 707”):
 - A) See attached manufacturer’s specifications and samples.
 - B) See attached certificate of manufacturer’s specifications meeting, and/or exceeding contract specifications.
 - C) See attached certificate of manufacturer’s excellence of quality and testing.
 - D) All wick drain material will be wrapped on each pallet with shrink wrap material (“black” to protect from ultra-violet rays). Each roll will be marked with the product label “Soil Drain 707”, and will be shipped to the job-site directly from the manufacturer, U.S. Drain, Inc. in Wilmington, N.C.

“Installation Equipment”

7. Pre-Augering Method:

We submit to use an APE Model 20 auger, consisting of a fixed mast system to support the Model 20, and 35 feet of 8 inch continuous flight auger. The Model 20 delivers up to 20,000 ft-lbs of torque. The auger will have a gear-driven crowding system to move the auger drive in and out of the ground. We will be using an aggressive cutter head to move and lift the hard dense soil layers. If large obstructions are discovered and not represented in the borings, then other method may be necessary. This auger system will attach to an excavator boom (Cat 330 for example).

“Installation Equipment”

8. Overcoming Obstructions:

- A) If obstructions are encountered near the working surface, extract the mandrel, move over one foot and try inserting mandrel again.
- B) If obstruction continues, repeat Item A.
- C) If obstruction persists, move to next defined wick location and insert mandrel.
- D) If new defined wick location is obstructed, repeat steps A-B until successful. This will allow the wick rig to define or outline the obstructed area. Then we can bring in the specified pre-auger and attempt to remove the obstruction to enable successful installation of the vertical wick drain.

“Installation Equipment”

9. Level Working Platform:

A) The site must be dressed and prepared using a dozer, grader and/or other necessary equipment to allow the installation equipment flat, stable ground to work from. This is necessary to keep the wick drain mast plumb for proper spacing during installation of the drains. A 1-2% grade is acceptable. The low side is always better to keep wear and tear out of the rig and rains at the proper locations.

B) Some instances may require the contractor to fill areas or even cut areas down, but the site must be as level and smooth as possible.

C) If terracing is necessary to reach or allow for installation equipment to install drains, then the contractor will work with the installer to insure an acceptable working platform.

“Installation Equipment”

10. Material References

The previously specified material U.S. Wick Drain’s “Soil Drain 707” has been successfully used on numerous projects throughout the United States. A few representative jobs are:

- a) Route 147, Wildwood, N.J., owner New Jersey DOT
1.3 million lineal feet
- b) Route 45, Salem County N.J., owner New Jersey DOT
- c) Route 120, East Ruthford, N.J., owner New Jersey DOT
- d) Wando Terminal, Charleston, S.C., owner South Carolina State Port Authority
- e) BFI Landfill, Richmond, Va., owner B.F.I.
- f) U.S. Army Corps of Engineers, Craney Island, VA